



Test Plug Adapter Kits

Cherne i2-Series

Technical Specification



Specifications

Cherne® i2-Series Test Plug Adapter Kits are designed for use with i2-Series Flow-Through Plugs for line acceptance tests and leak location testing. Caps are made of durable, rust resistant PVC. Color-coded inflation ports match the plug with the hose and panel system.



Test Plug

Test plug adapter kit is selected based upon Flow-through Plug bypass size and desired connection style to create complete Test Plug.

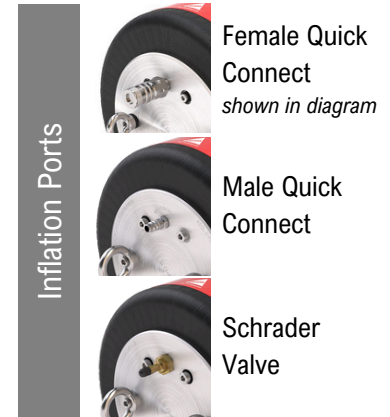

Product No.	Description	Dim A (mm)	Dim B (mm)	Dim C (BSP)
Adapter Kit with Female Quick Disconnect Inflation Port				
417018	1/2" Bypass Adapter Kit	27,53	103,88	1/2" / 1.27 cm
417028	2" Bypass Adapter Kit	71,63	95,38	50 mm / 2"
417038	3" Bypass Adapter Kit	100,69	137,10	75 mm / 3"
417048	4" Bypass Adapter Kit	129,03	126,00	100 mm / 4"
417068	6" Bypass Adapter Kit	183,80	132,10	150 mm / 6"
Adapter Kit with Male Quick Disconnect Inflation Port				
M417018	1/2" Bypass Adapter Kit	27,53	76,62	1/2" / 1.27 cm
M417028	2" Bypass Adapter Kit	71,63	70,57	50 mm / 2"
M417038	3" Bypass Adapter Kit	100,69	110,20	75 mm / 3"
M417048	4" Bypass Adapter Kit	129,03	99,70	100 mm / 4"
M417068	6" Bypass Adapter Kit	183,80	106,10	150 mm / 6"
Adapter Kit with Schrader Valve Inflation Port				
S417018	1/2" Bypass Adapter Kit	27,53	77,32	1/2" / 1.27 cm
S417028	2" Bypass Adapter Kit	71,63	72,97	50 mm / 2"
S417038	3" Bypass Adapter Kit	100,69	111,30	75 mm / 3"
S417048	4" Bypass Adapter Kit	129,03	100,30	100 mm / 4"
S417068	6" Bypass Adapter Kit	183,80	107,10	150 mm / 6"

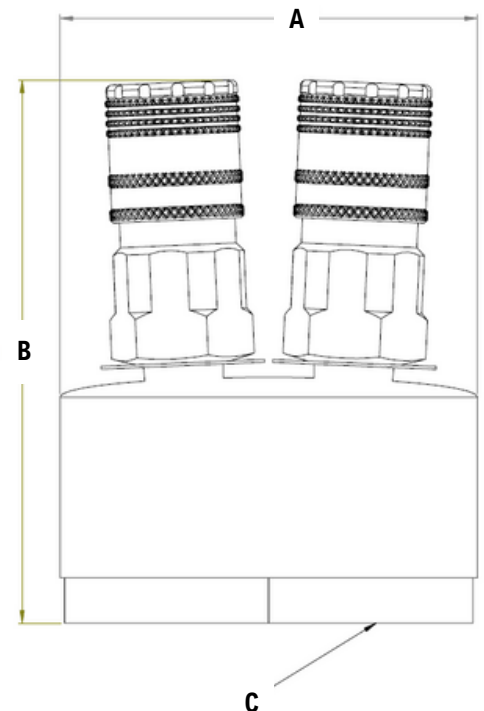



Test Plug Adapter Kit Cherne i2-Series Technical Specification

Line Acceptance Test

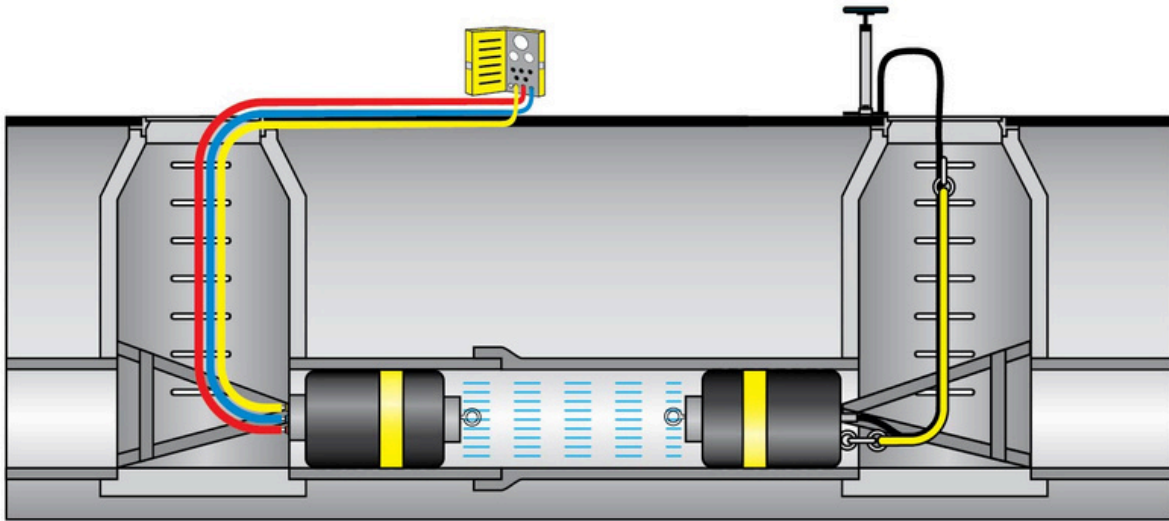

i2-Series Accessories

Product No.	Description
Triple Hose	
457258	7,6m (25ft) with Male Quick Connect Fitting Triple Hose
M457258	7,6m (25ft) with Female Quick Connect Fitting Triple Hose
S457258	7,6m (25ft) with Schrader Valve Connections Triple Hose
457508	15,2m (50ft) with Male Quick Connect Fitting Triple Hose
M457508	15,2m (50ft) with Female Quick Connect Fitting Triple Hose
S457508	15,2m (50ft) with Schrader Valve Connections Triple Hose
Control Panel	
304718	Control Panel
314718	Digital Control Panel

